

Construction Guidelines

- ❑ All load bearing posts must be anchored to footings with stirrup, bolt, or other approved fastener.
- ❑ All wood that comes in contact with the ground must be termite and decay resistant. Examples: Cedar, Redwood, or pressure treated.
- ❑ Joist hangers are required to be secured with an approved fastener at band board and ledger connections.
- ❑ Attach band boards to houses with approved fastener Per table
- ❑ Guard rails are required when deck surface to grade exceeds 30" at any point within 36" from deck.
- ❑ Stairs shall have minimum 10" treads and maximum 7 3/4" risers with 4" maximum openings.
- ❑ Stairs with four (4) or more risers require a graspable handrail. Graspable handrails shall start at the nose of the first tread and be continuous to the nose of the last tread and shall be installed between 34" to 38" vertically above the nosing of the treads and shall have a return.
- ❑ All overhead electrical wires must be at least 12' above the deck floor.
- ❑ Guardrail minimum height 36"
- ❑ Deck cantilever depends on type of construction
- ❑ All balconies, decks, and porches shall have at least one receptacle outlet installed within their perimeter

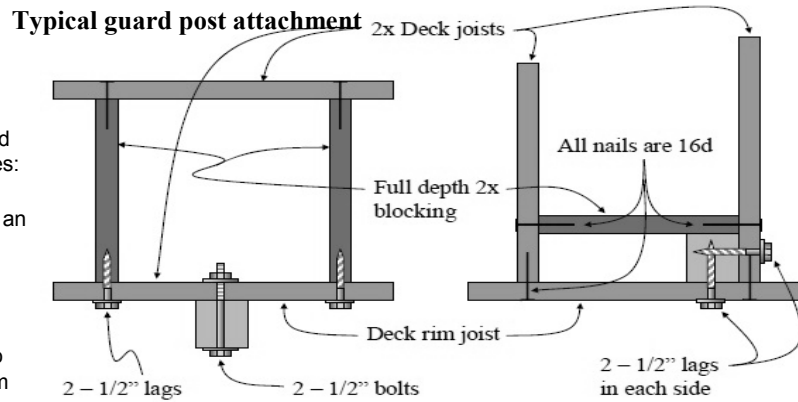

Typical types of footings, may be belled at bottom

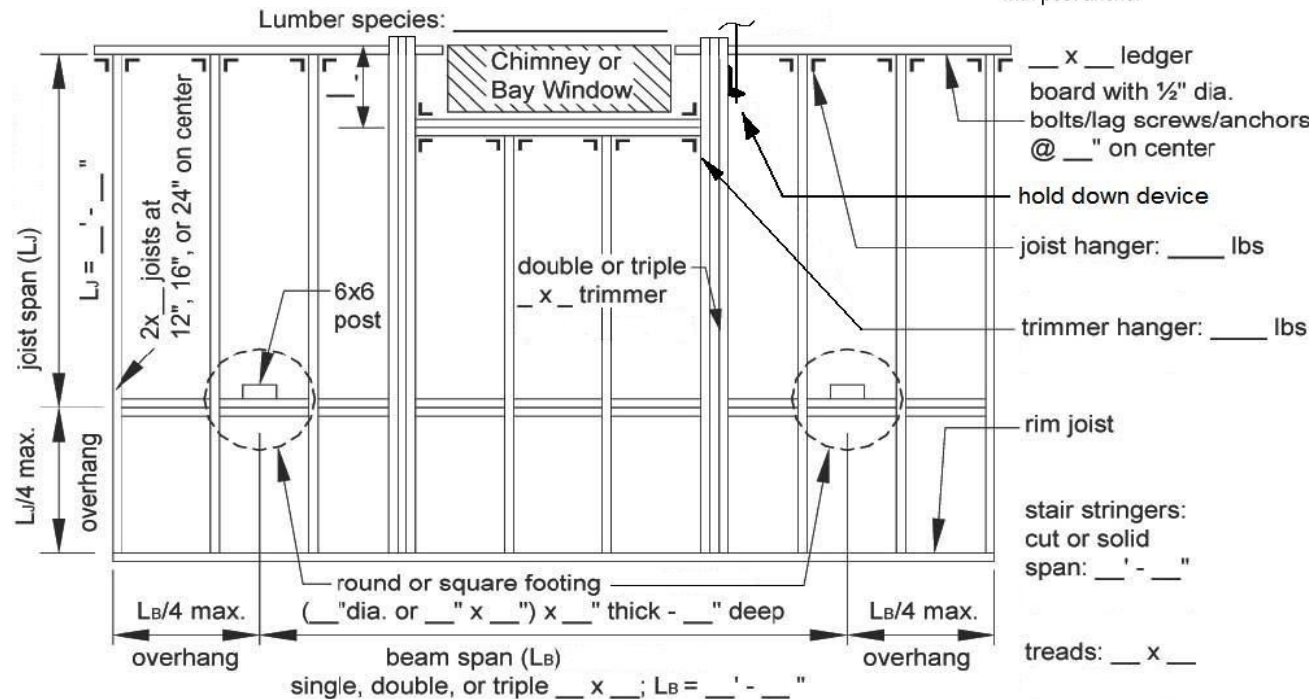
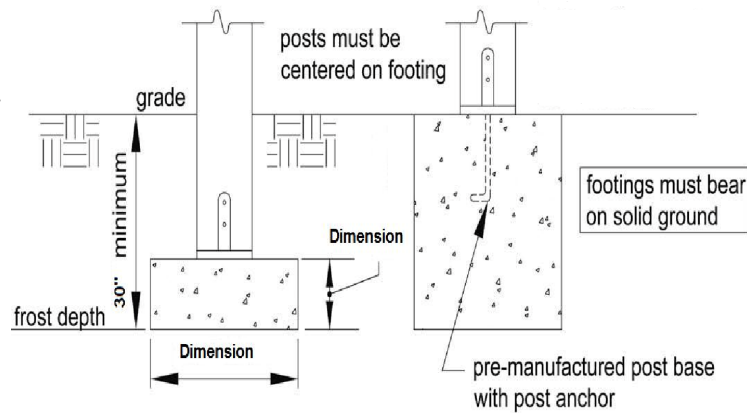

The City of O'Fallon's Community Development Department supports and encourages every resident's decision to improve their home. Approval of plans and inspection of work being done helps ensure your home improvement project meets minimum code requirements while improving your property.

We look forward to helping you.

Director of Building Safety

Inspections: The City may conduct **Footing, and Framing inspections** as required by your specific project and **Final Inspections** of all decks. Check your approved plans from the City for a list of required inspections for your project.

(636) 379-5595 Inspection Line
Inspections called in by 4:00 p.m. will be on the next business day's schedule.

City permit approval does not constitute subdivision approval. The City recommends you contact trustees in your subdivision for any subdivision requirements.

This is a general guide for the construction of a deck within the City of O'Fallon, Mo. All code requirements are too extensive to list within this guide. For specific questions or further information, please contact the **Building Safety Department at (636) 379-5660**

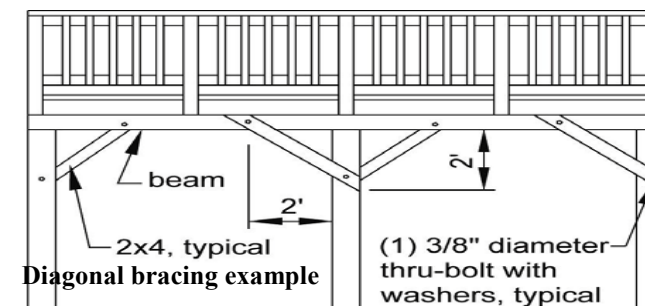

Deck Guide

City of O'Fallon, Missouri
Building Department
100 North Main Street
O'Fallon, MO, 63366
(636) 379-5660
www.ofallon.mo.us

Obtaining a Permit

Two copies of plans with the below information is necessary for obtaining a deck permit:

SITE PLANS

- Provide a scaled copy of your Plot Plan or Survey with the deck indicated as proposed. Show cantilevers on house and all easements and setbacks. Rear setbacks: deck must be a minimum ten feet from the rear property line. Side setbacks: deck must remain out of the approved side yard setback. No portion of the deck shall extend into an easement, including stairs and cantilevers.

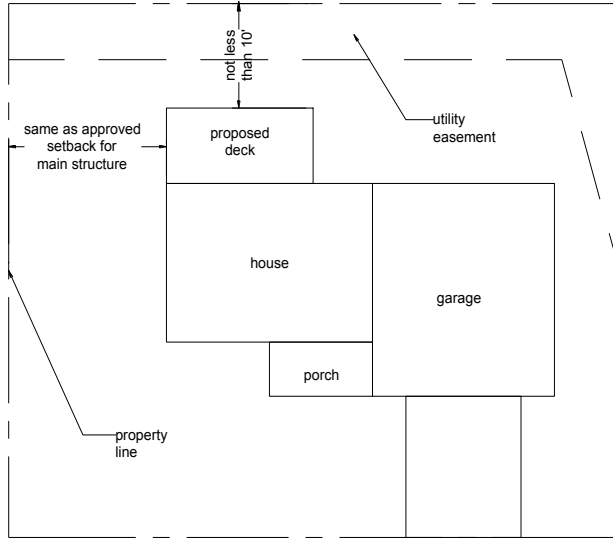

CONSTRUCTION PLANS

General: All plans must be drawn to scale and must include the following to be considered for review, see illustrations for examples

- Deck dimensions and elevation
- Lumber size and type of house joists/bandboard
- Joist spans (length of joist to beams or supports)
- Joist spacing (distance between joist)
- Pier/footing depth and size
- Post size, post length, detail of post to beam and post to pier attachment, beam size
- Guardrail detail, fastening to deck, materials and spacing, minimum height 36"
- Existing or new electric receptacle location

Deck Attachment to House:

- Approved fastener diameter, length, and spacing
- Detail of ledger attachment and method of attachment at cantilevers

A Stair Detail:

- Tread and rise measurement
- Guard rail height and respective spacing
- Spindle spacing
- Hand rail height and diameter

Important Framing Requirements

All beams, girders, and trimmer joists used to frame around bays or cantilevers or other construction methods **MUST** bear on the existing house wall and **MAY NOT** be supported on the deck ledger with hangers or fasteners. Alternatively, they may be attached directly to the house bandboard with approved hangers, supported by posts and piers, or deck joists at cantilevers may be independently run inside and rest on the existing wall plate or be constructed as a freestanding deck by post and beam construction. All decks will be required to be laterally braced with approved hold down tension devices at a minimum of two locations or diagonal bracing. Decks attached to homes with I-Joists must be laterally braced at each end and at 10' O.C with approved tension devices. Opposing lateral bracing can be achieved by installing decking at a 45 degrees or installing diagonal (X or K) bracing at each post.

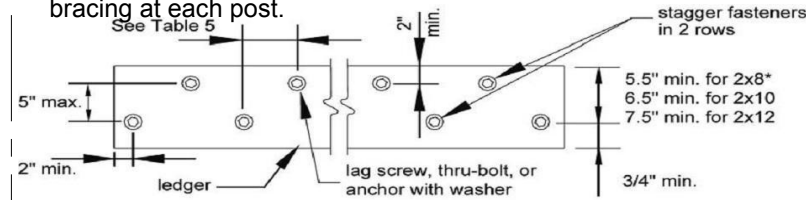

Ledger attachment

Table 5. Fastener Spacing for a Southern Pine, Douglas Fir-Larch, or Hem-Fir Deck Ledger and a 2-inch Nominal Solid-Sawn Spruce-Pine-Fir^{7,9} Band Joist or EWP Rim Board⁶
(Deck Live Load = 40 psf, Deck Dead Load = 10 psf)^{3,6}

Joist Span	Rim Board or Band Joist	On-Center Spacing of Fasteners ^{4,5}						
		6'-0" and less	6'-1" to 8'-0"	8'-1" to 10'-0"	10'-1" to 12'-0"	12'-1" to 14'-0"	14'-1" to 16'-0"	16'-1" to 18'-0"
1/2" diameter lag screw with 15/32" maximum sheathing ¹	1" EWP ⁶	24"	18"	14"	12"	10"	9"	8"
	1-1/8" EWP ⁶	28"	21"	16"	14"	12"	10"	9"
1/2" diameter bolt with 15/32" maximum sheathing	1-1/2" Lumber ^{7,9}	30"	23"	18"	15"	13"	11"	10"
	1" EWP ⁶	24"	18"	14"	12"	10"	9"	8"
1/2" diameter bolt with 15/32" maximum sheathing and 1/2" stacked washers ^{2,8}	1-1/8" EWP ⁶	28"	21"	16"	14"	12"	10"	9"
	1-1/2" Lumber ^{7,9}	36"	36"	29"	24"	21"	19"	16"

1 The tip of the lag screw shall fully extend beyond the inside face of the band joist.
 2 The maximum gap between the face of the ledger board and face of the wall sheathing shall be 1/2".
 3 Ledgers shall be flashed and caulked to prevent water from contacting the house band joist.
 4 Lag screws and bolts shall be staggered.
 5 Deck ledgers shall be minimum 2x8 pressure-preservative-treated No.2 grade lumber, or other approved materials as established by standard engineering practice.
 6 When solid-sawn pressure-preservative-treated deck ledgers are attached to engineered wood products (minimum 1" thick wood structural panel band joist or structural composite lumber including laminated veneer lumber), the ledger attachment shall be designed in accordance with accepted engineering practice. Tabulated values based on 300 lbs and 350 lbs for 1" and 1-1/8" EWP rim board, respectively.
 7 A minimum 1"x9 1/2" Douglas fir-larch laminated veneer lumber rim board shall be permitted in lieu of the 2" nominal band joist.
 8 Wood structural panel sheathing, gypsum board sheathing, or foam sheathing not exceeding one inch thickness shall be permitted.
 9 Fastener spacing also applies to southern pine, Douglas fir-larch, and hem-fir band joists.

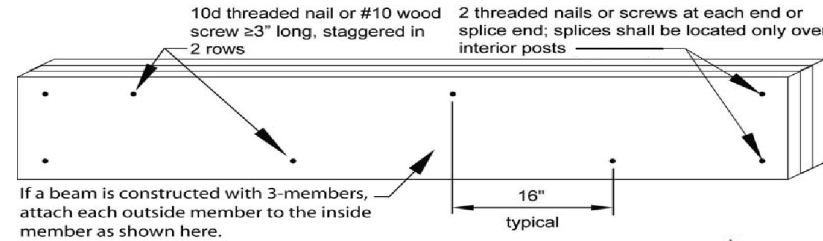
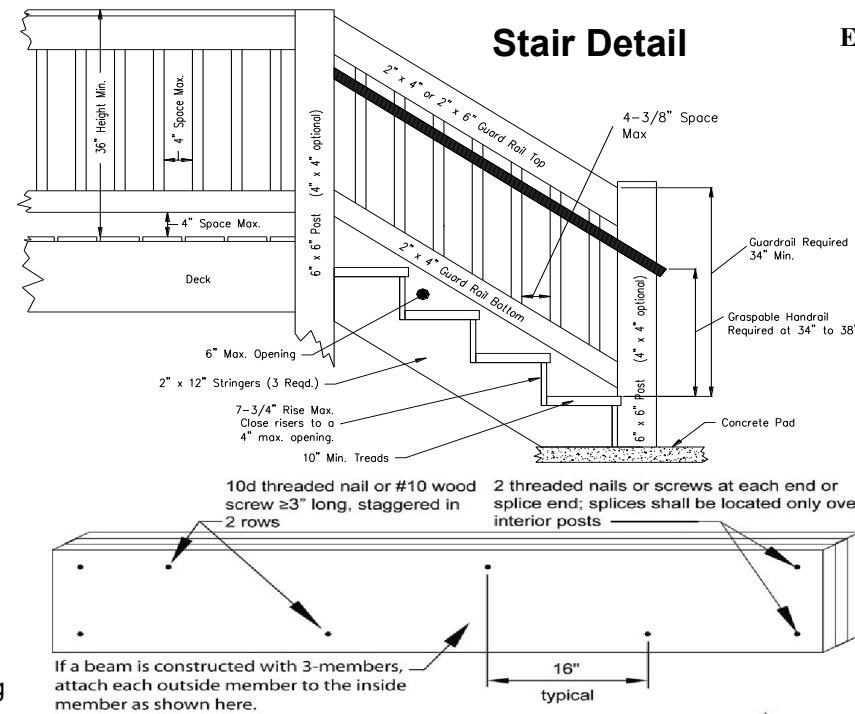

Example handrails, other styles may comply

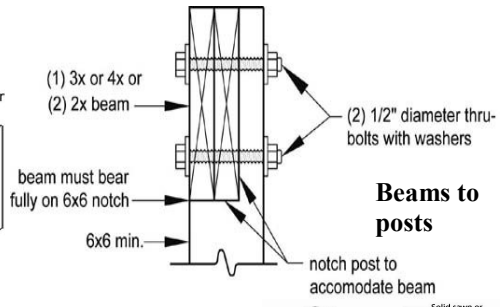
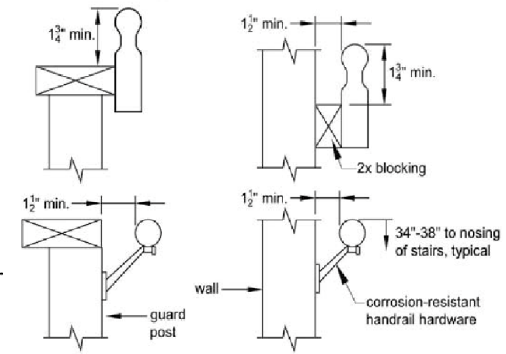

Beams to posts

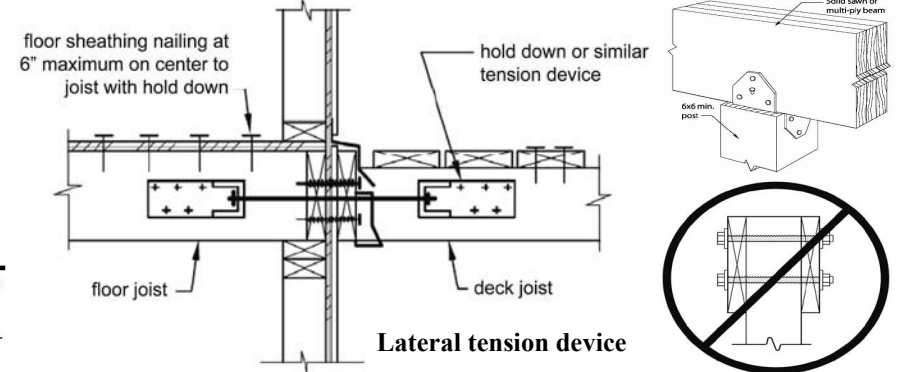

Lateral tension device

Flashing detail

The following information must be included on all deck plans for consideration of code review:

All decks will need:

- ✓ **The type of floor joists in your home MUST be included**
- ✓ A plot plan showing the placement of your deck
- ✓ A framing plan drawn to scale
- ✓ An elevation plan drawn to scale
- ✓ Dimensions of deck perimeter, beam location, post/pier location
- ✓ All framing material sizes, spans and spacing
- ✓ Decking size and span rating if composite
- ✓ Size and type of house band and joists with method of attachment of deck ledger to band board
- ✓ Flashing detail
- ✓ Stair detail with measurements
- ✓ Guardrail detail with method of attachment
- ✓ Footing/pier detail with size and depth, and post to pier attachment
- ✓ Beam to post attachment detail
- ✓ Method of lateral load bracing (parallel to house)

Decks with bays/cantilevers will also need:

- ✓ Width and depth of cantilever
- ✓ Size and number of trimmer and header joists (“H” Framing)
- ✓ Method of support of trimmer joists at house
- ✓ Method of lateral load bracing (perpendicular to house)

Freestanding decks will also need:

- ✓ Method of uplift resistance
- ✓ Method of lateral load bracing (parallel and perpendicular)